

3M Purification

3M™ TFS450

Reverse Osmosis System



The 3M™ Water Filtration Products TFS450 Reverse Osmosis Water Filtration System helps produce consistent Recipe Quality Water™ for hot beverages and steamers while maintaining efficient equipment operations in water conditions with high total dissolved solids (TDS) and/or hardness. The unique design allows for filtered water to be blended with RO water for adjustment of beverage quality and production volumes to about 2,271 litres/day.

The TFS450 offerings include three modules for maximum flexibility. The central Membrane Module is supported by an alternative Pumping Module to boost inlet water pressure when required and a choice of two product water storage tanks.

On-line TDS monitoring and pressure gauges are included. An installation kit is available.

Features & Benefits

- Precision lockable, metering valve provides Recipe Quality Water™ with adjustable Total Dissolved Solids (TDS)¹ for coffee and espresso brewing.
- Reduced equipment maintenance and replacement costs from reduced minerals that cause lime scale.
- Daily production from 1,136 litres /day with no blending up to 2,271 litres /day with blending.²
- Conversion of inlet water to product water (water utilization efficiency) is at least 50%; higher with blending.²
- Lower product-water recovery times with the included permeate pump.
- A hydraulic (non-electrical) bypass valve maintains the water flow in high demand situations.
- All product water (including blending and bypass) is pre- and post-filtered with NSF listed carbon and sediment filters, if desired, for cyst reduction and great taste.
- System includes built-in pressure gauges and an in-line product-water TDS meter for monitoring.

Applications

- Coffee
- Espresso
- Steamers



Product Specifications

Model	Part Number	Reduction Claims	Capacity	Service Flow Rate	Application
TFS450	70020217751	Approx. 90% TDS Reduction ⁴	132,489 litres	12.6 lpm	Coffee, Espresso, Steamers

NOTE: Softening is recommended when inlet feed water hardness is over 10 grains (171 ppm) and/or when inlet total dissolved solids are > 1,400 ppm.
 1. From 10% to about 50% of inlet-water TDS. 2. Capacity/Conversion is at 77°F (25°C) and 70 psi feedwater pressure to atmosphere without blending. With blending the system production rate is approximately doubled and the maximum outlet water Total Dissolved Solids (TDS) is about 50% of inlet water TDS. Performance may vary depending on water temperature and pressure. 3. Also available without pre-filter and post-filter as part number 5623902. 4. Without blending.

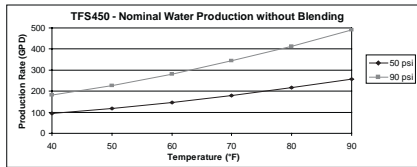
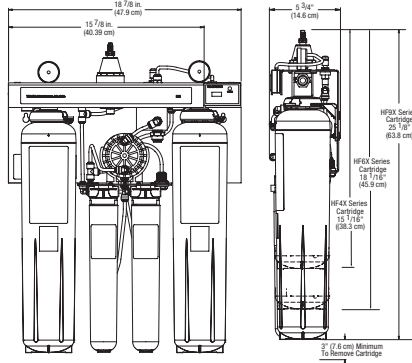

Replacement Cartridges

Part No	Function	Description	Qty Req
70020020155	Pre-filter	HF95	1
70020121433	Final (Post) Filter	HF90	1
70020150713	RO Filter	RO Membrane	2

Physical Specifications

- System materials are NSF and/or FDA CFR-21 compliant.
- System is mountable with a powder-coated rust-resistant bracket design.
- Pumping Module connections are 3/8" NPT (female) and include 1/2" NPT bushings.
- Membrane Module inlet/outlet connections are 1/2" NPT (female).
- Maximum inlet water pressure of 100 psi (689 kPa) and inlet water temperature of 37.8°C.

IMPORTANT: Installation Tips

These installation tips are for informational purposes only and are not intended to be used as actual installation instructions.

CAUTION: To reduce the risk associated with property damage due to water leakage:

- Read and follow. Use Instructions before installation and use of this system.
- Installation and use. MUST comply with all state and local plumbing codes.
- Protect from freezing, remove filter cartridge when temperatures are expected to drop below 4.4°C (40°F).
- Do not install on hot water supply lines. The maximum operating water temperature of this filter system is 37.8°C (100°F).
- Do not install if water pressure exceeds 862 kPa (125 psi). As a requirement of the plumbing code, a pressure limiting valve and backflow prevention device must be installed. Contact a plumbing professional if you are uncertain how to check your water pressure.
- Do not install where water hammer conditions may occur. If water hammer conditions exist you must install a water hammer arrester. Contact a plumbing professional if you are uncertain how to check for this condition.
- The disposable filter cartridge MUST be replaced every 12 months, at the rated capacity or if a noticeable reduction in flow rate occurs.

WARNING: Do not use with water that is microbiologically unsafe or of unknown quality without adequate disinfection before or after the system. If system is not used for 2 days or more, flush 5-10 litres of water through before consuming water.

Important Notice

The information described in this literature is accurate to the best of our knowledge. A variety of factors, however, can affect the performance of the Product(s) in a particular application, some of which are uniquely within your knowledge and control. INFORMATION IS SUPPLIED UPON THE CONDITION THAT THE PERSONS RECEIVING THE SAME WILL MAKE THEIR OWN DETERMINATION AS TO ITS SUITABILITY FOR THEIR USE. IN NO EVENT WILL 3M PURIFICATION BE RESPONSIBLE FOR DAMAGES OF ANY NATURE WHATSOEVER RESULTING FROM THE USE OF OR RELIANCE UPON INFORMATION. It is your responsibility to determine if additional testing or information is required and if this product is fit for a particular purpose and suitable in your specific application.

Limitation of Liability

3M Purification Pty Limited will not be liable, to the extent permitted by law, for any loss or damage from the use of the Product(s), whether direct, indirect, special, or consequential, regardless of the legal theory asserted, included warranty, contract, negligence or strict liability.



3M Purification Pty Limited

140 Sunnyholt Road
 Blacktown NSW 2148
 Australia
 Tel: 1300 367 362
 Fax: 1800 671 599
www.3mpurification.com.au

3M New Zealand

94 Apollo Drive
 Rosedale Auckland 0632
 New Zealand
 Tel: 0800 362 886
 Fax: 0800 362 880
www.3M.com/nz

3M is a trademark of the 3M Company.

Please recycle. Printed in Australia.

© 3M 2014. All rights reserved.

AV011434378